



SWISS QUALITY MADE
tecnopinz



2023 CATALOGUE

ETS / ETA Collets and Nuts

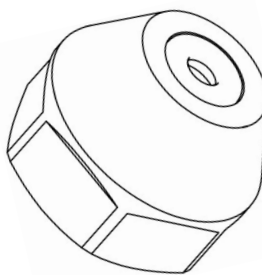
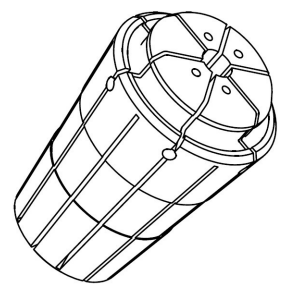
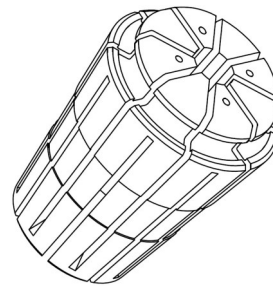
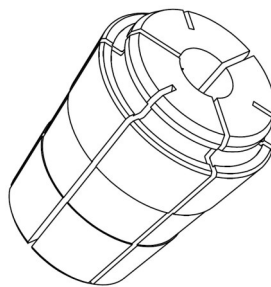
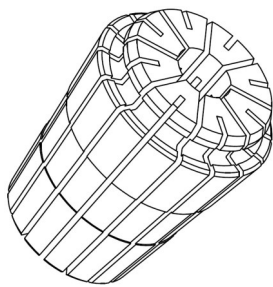

In a world of imperfection, go for the least one



SWISS QUALITY MADE
tecnopinz



SALES CONDITIONS

1. General Terms, Validity Areas

All offers, deliveries and other services provided by Tecnopin SA (TP SA) are subject to the sales and delivery conditions as outlined below. If there is no written agreement between the parties (supplier and buyer) the conditions set forth here will be applied to all purchase orders. Any change of these conditions is subject to acceptance through a written agreement between the parties (supplier and buyer).

2. Customer Information Obligation

The customer is set to inform TP SA before the conclusion of the contract if the product:
Is provided for a use other than its standard application and/or is applied in unusual conditions which can create security and safety risks for people and environment and/or is used for machining of unusual materials.

3. Ending and content of the contract

The validity of the offers released by TP SA is 30 days, if not differently specified in the official offer document. The object of the contract will be defined through the product description given in the official offer and order confirmation. The validity of supplementary agreements, oral statements from employees or agents acting for TP SA, as well as edits of existing orders (including edits on the delivery of products) are subject to prior written confirmation by the manufacturer.

4. Prices and Payments

Without specific provisions the prices are considered as "Ex Works" (EXW), Mezzovico (CH) -without packaging and duties unpaid". Payments must be made in the currency indicated in the offer and related order confirmation, without any deduction from the invoice's total amount and have to be settled to the bank account indicated on the invoice. Regardless of the type of payment it will be considered settled when the full invoice amount is irrevocably credited to the bank account indicated on the invoice. All costs resulting from the chosen payment system are entirely under the buyer's responsibility.

In case of delays or missing payment by the purchaser within the agreed timetable, TP SA reserves the right to claim a default interest of 6% above the interest rate of refinancing of the European Central Bank, independent of other legal remedies. TP SA may at any time provide evidence of any further damage occurring.

5. Delivery Time, Reception of the Goods.

The delivery time has no value commitment and doesn't give any right to require a payment of a penalty. The delivery time can exceed the previously confirmed delivery term if TP SA is unable to fulfil it due to reasons not related to their field of influence, or for reasons of which TP SA was not aware at the conclusion of the purchase contract. In particular, events such as late or incorrect deliveries from subcontractors are considered outside the field of TP SA's influence. The beginning and the end of the unlikely event will be always communicated as soon as possible. If the delivery delay exceeds three months there is the possibility,

either by the buyer or by TP SA, to cancel the purchase contract. If TP SA becomes aware, after the conclusion of the contract, of events and information that put into serious doubt the buyer's payment ability and moreover TP SA could be endangered as result of these information, TP SA may refuse to execute the contract until payment is received, or until receipt of strong guarantees from the buyer and/or receipt of any other payments that has a commercial relation, on TP SA its point of view, with the contested purchase contract.

In the absence of any other agreement the buyer agrees to collect the ordered product within ten days (10) from the receipt of a "ready for shipment notice" by TP SA. If this period is exceeded by more than three days (3), regardless of any other legal measures, TP SA will be allowed to deliver and therefore conclude its sales activity. The non-acceptance of the delivered goods has no effect on the duty of the buyer to pay the purchase price of the mentioned delivered goods and related invoice.

6. Deliveries, Shipping, Transfer of Risks

The place of delivery is determined by agreement between the buyer and TP SA, together with the conditions of the transaction, which must be presented in accordance with Incoterms 2000. If there are no specific terms of delivery it is performed as ex works (EXW). In the absence of any other agreement, the risk taking of the goods is transferred to the buyer when the goods are made available by the manufacturer. If the goods are shipped to the buyer, the risk of goods passes to the buyer, at the latest when the first carrier receives the goods. If the shipment of the goods is delayed by circumstances, which TP SA is not responsible for, the risk passes to the buyer by the time the availability of goods is notified. All deliveries will be at the expense of the buyer himself.

7. Responsibility, Damage Compensation

TP SA is not liable for damages, particularly when pecuniary damages occur as a result of one or more late deliveries, or in case of non-conformity of delivered goods or documents related to the purchase contract.

8. Property

All the delivered goods, regardless of the shipment destination and procedure, remain property of TP SA until full payment of the confirmed and accepted purchase price by the buyer.

9. Jurisdiction, Applicable Law

For all disputes arising from the contract, the legal court reference is CH-6900 Lugano. Tecnopin SA reserves the right to pursue legal actions against the purchaser with legal jurisdiction in its location. These sales and delivery conditions, as well all relations with the legal contractor, are governed by the Swiss Law.

CH-6805 Mezzovico,
Valid from November 1st 2016



SWISS QUALITY MADE
tecnopinz



ETS / ETA Self-Centering Collets and Nuts

The ETS & ETA Collets and Nuts are an exclusive brand of Tecnopinz, which invented its own high-precision tool holders, in order to offer the most efficient solution for the high-end manufacturing industry.

Features

- 100% made in Switzerland
- Unmatched accuracy thanks to the self-centering geometry
- Fully compatible and interchangeable with all DIN6499 ER Tool-Holders
- Easy assembly procedure
- Uniform gripping pressure at any speed
- Precise tool centering and high rigidity for precision cutting
- Extended tooling lifetime

Convert to ETS / ETA Self-Centering System

- Simply purchase the appropriate ETS Collet and ETS Nut for your chosen tool-holders
- ⇒ Conversion example: ER16 Collet $\varnothing 3.00\text{mm}$ = ETS16 Collet $\varnothing 3.00\text{mm}$
- ⇒ Conversion example: ER16 Nut M22 x 1.50mm = ETS16 Nut M22 x 1.50mm



IMPORTANT Always make sure that the purchased collets and nuts have the original **TP** logo marked on the front surface!



SWISS QUALITY MADE
tecnopinz



ETS / ETA Self-Centering Collets and Nuts

Ultra Precision (UP) ETS & ETA Collets

In many market sectors, precision is synonymous with increase competitiveness and greater customer satisfaction. For machining requiring the highest accuracy, Tecnopinz offers the Ultra Precision (UP) version, available for both ETS and ETA geometries and able to operate with runout values below three thousandths of a millimetre (0,003mm).

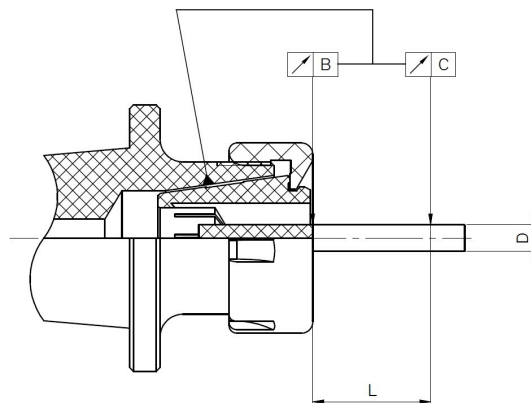

Static Concentricity		DIN-6499	ETS & ETA Standard	ETS & ETA Ultra Precision	
D	L	C MAX	C MAX	B MAX	C MAX
0.20 - 0.60	3.00	0.015	0.010	-	-
0.70 - 0.90	3.00	0.015	0.010	0.003	0.005
1.00 - 1.40	6.00	0.020	0.010	0.003	0.005
1.50 - 2.90	10.00	0.020	0.015	0.003	0.005
3.00 - 6.00	16.00	0.020	0.015	0.003	0.005
6.50 - 10.00	25.00	0.020	0.015	0.003	0.005
11.00 - 18.00	40.00	0.030	0.020	0.004	0.008
19.00 - 26.00	50.00	0.030	0.020	0.005	0.010



SWISS QUALITY MADE
tecnopin



ETS / ETA Self-Centering Collets and Nuts

Collets

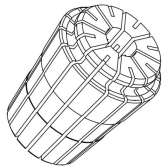

ETS Geometry

The ETS geometry sets a reference for the world of precision mechanics. ETS collets are suitable for all processes requiring a high level of accuracy with tool-shank diameters from 1,00 mm to 26,00 mm

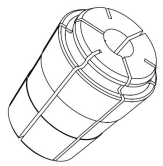

ETA Geometry

Designed specifically for extremely precise and high-speed machining; for tools with a minimum tool shank diameter of 0,20 mm. Fewer cuts make it possible to work at speeds up to 100'000 rpm.

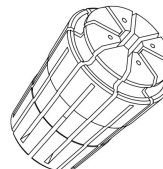

ETS SPRAY Collet

This version has the same features and advantages of the standard ETS collet and ensures direct spraying of the coolant onto the tool, thanks to the 4 bore holes specifically proportioned to the bore diameter.

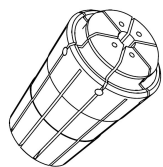

ETS SPRAY HSM Collet

This version has the same features and advantages of the ETS SPRAY collet. It has been engineered for the high speed milling machining, ensuring a direct spraying of the coolant onto the tool with operating speeds up to 20'000 rpm.

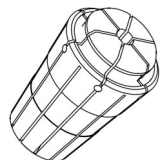

ETS HERMETIC COLLETS

Ideal for the use of inner-cooled tools on extremely reduced operating spaces inside the machine. This solution ensures the same application as the ETS FLUID nut without need of any additional device and it is fully compatible with standard ETS nuts.



SWISS QUALITY MADE
tecnopinz



ETS / ETA Self-Centering Collets and Nuts

Nuts

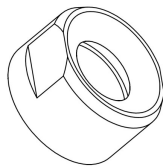

ETS Nut

Essential for ensuring correct coupling between ETS and ETA collets and the collet holder; with its reduced size, this nut allows to work as closely as possible to the work piece providing high rigidity for precision cutting.



ETS Nut

This version has the same features and advantages of the standard ETS and its design with six cuts is compatible with specific spanners used for a precise coupling on the tool-holding system.

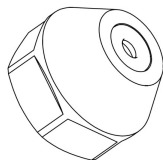

ETS Fluid Nut

Based on the standard model, the ETS fluid nut has been designed to ensure the overall sealing of the tool-clamping system, by channelling the passage of coolant solely through the tool.

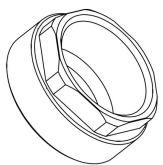

ETS External Thread Nut

This version has been developed in order to enable the application of ETS and ETA collets to tool holders with inner thread, thus reducing the required space and vibrations to a minimum.



SWISS QUALITY MADE
tecnopin



ETS / ETA Self-Centering Collets and Nuts

ETS FLUID Nuts Application

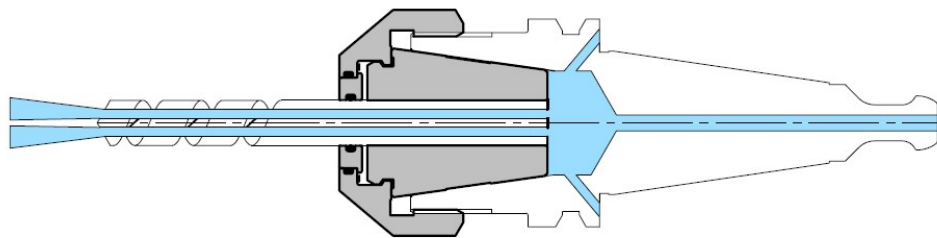
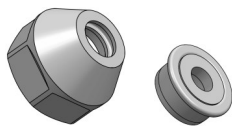

ETS SPRAY and ETS SPRAY HSM Collets Application

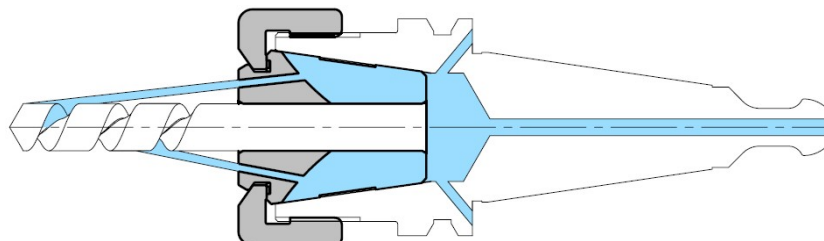
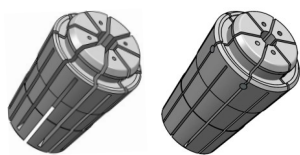



SWISS QUALITY MADE
tecnopin



ETS / ETA Self-Centering Collets and Nuts

ETS HERMETIC Collets Application

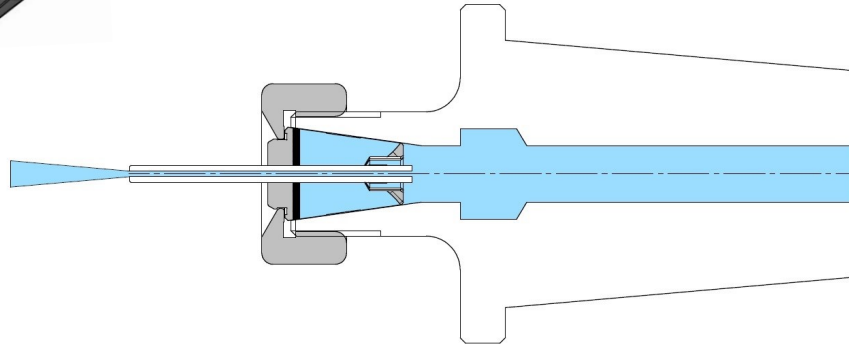

IMPORTANT Always make sure that the purchased collets and nuts have the original **TP** logo marked on the front surface!

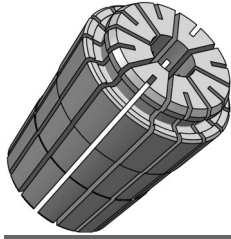

SWISS QUALITY MADE
tecnopinz



ETS COLLETS

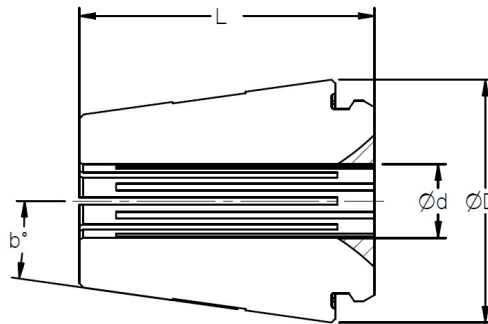
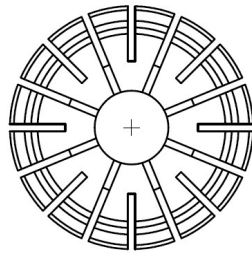

(Dimensions are in mm)

Type	Ød	ØD	Clamping Range	L	b°	Reference Number
Type	Ød	ØD	Plage de Serrage	L	b°	Numéro Référence
Typ	Ød	ØD	Spann Bereich	L	b°	Bestell Nummer
ETS 8	1.25 - 2.75 3.00 - 4.00	8.00	0.25 0.50	13.00	8°	1108.0000
ETS 9	1.25 - 2.75 3.00 - 5.00	9.00	0.25 0.50	13.00	8°	1109.0000
ETS 10	1.25 - 2.75 3.00 - 5.00	10.00	0.25 0.50	14.00	8°	1110.0000
ETS 12	1.25 - 2.75 3.00 - 4.50 5.00 - 7.00	11.00	0.25 0.50 1.00	17.00	8°	1112.0000
ETS 14	1.25 - 2.75 3.00 - 4.50 5.00 - 8.00	14.00	0.25 0.50 1.00	20.00	8°	1114.0000
ETS 16	1.25 - 2.75 3.00 - 4.50 5.00 - 10.00	16.00	0.25 0.50 1.00	24.00	8°	1116.0000
ETS 20	1.00 - 2.75 3.00 - 4.50 5.00 - 13.00	20.00	0.25 0.50 1.00	30.00	8°	1120.0000
ETS 25	1.00 - 2.75 3.00 - 4.50 5.00 - 16.00	25.00	0.25 0.50 1.00	34.00	8°	1125.0000
ETS 32	1.50 - 4.50 5.00 - 20.00	32.00	0.50 1.00	40.00	8°	1132.0000
ETS 40	4.00 - 4.50 5.00 - 26.00	40.00	0.50 1.00	45.00	8°	1140.0000

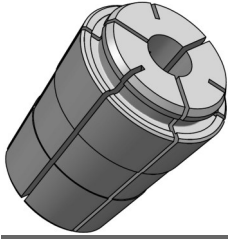

SWISS QUALITY MADE
tecnopin



ETA COLLETS

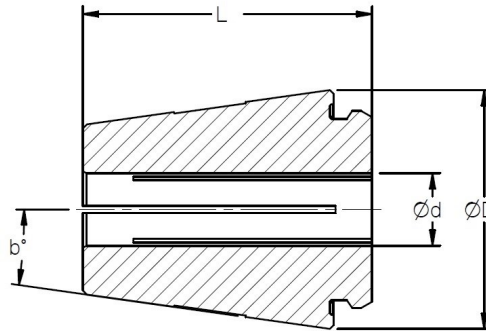
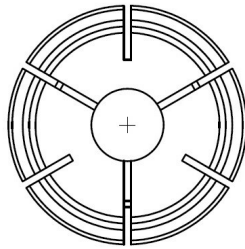

(Dimensions are in mm)

Type	Ød	ØD	Clamping Range	L	b°	Reference Number
Type	Ød	ØD	Plage de Serrage	L	b°	Numéro Référence
Typ	Ød	ØD	Spann Bereich	L	b°	Bestell Nummer
ETA 6	0.20 - 0.90 1.00 - 2.00	6.00	0.10 0.50	11.00	5°	1006.0000
ETA 8	0.20 - 0.90 1.00 - 4.00	8.00	0.10 0.50	13.00	5°	1008.0000
ETA 9	0.20 - 0.90 1.00 - 5.00	9.00	0.10 1.00	13.00	8°	1009.0000
ETA 10	0.20 - 0.90 1.00 - 5.00	10.00	0.10 1.00	14.00	8°	1010.0000
ETA 12	0.20 - 0.90 1.00 - 7.00	11.00	0.10 1.00	17.00	8°	1012.0000
ETA 14	0.20 - 0.90 1.00 - 8.00	14.00	0.10 1.00	20.00	8°	1014.0000
ETA 16	0.20 - 0.90 1.00 - 10.00	16.00	0.10 1.00	24.00	8°	1016.0000

Reference Number
(Example: ETA 16 - Ø0.30)

1016.0030

In a world of imperfection, go for the least one



SWISS QUALITY MADE
tecnopin



ETS SPRAY COLLETS

Up to 3'000 rpm

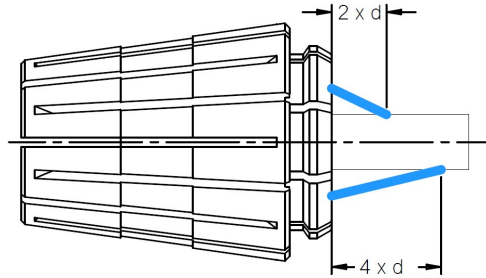
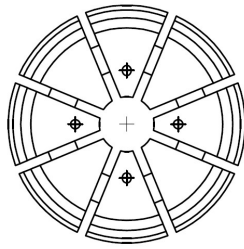

(Dimensions are in mm)

Type	$\varnothing d$	$\varnothing D$	Clamping Range	L	b°	Reference Number
Type	$\varnothing d$	$\varnothing D$	Plage de Serrage	L	b°	Numéro Référence
Typ	$\varnothing d$	$\varnothing D$	Spann Bereich	L	b°	Bestell Nummer
ETS 12	1.00 - 7.00	11.00	1.00	17.00	8°	1212.0000
ETS 14	1.00 - 8.00	14.00	1.00	20.50	8°	1214.0000
ETS 16	1.00 - 10.00	16.00	1.00	24.00	8°	1216.0000
ETS 20	1.00 - 13.00	20.00	1.00	30.50	8°	1220.0000
ETS 25	1.00 - 16.00	25.00	1.00	34.00	8°	1225.0000
ETS 32	2.00 - 20.00	32.00	1.00	40.00	8°	1232.0000
ETS 40	4.00 - 26.00	40.00	1.00	45.00	8°	1240.0000

Reference Number
(Example: ETS 16 - $\varnothing 3.00$)

1216.0300

In a world of imperfection, go for the least one



SWISS QUALITY MADE
tecnopin



ETS SPRAY HSM COLLETS

Up to 20'000 rpm

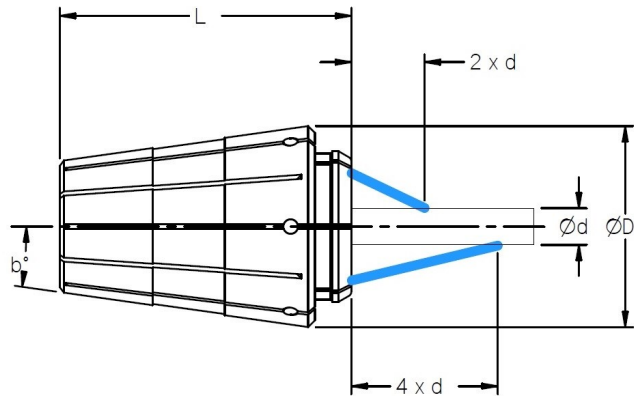
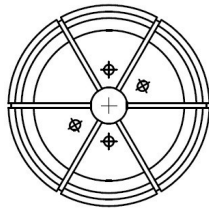

(Dimensions are in mm)

Type	Clamping Range	Reference Number				
Type	Plage de Serrage	Numéro Référence				
Typ	Spann Bereich	Bestell Nummer				
	Ød	ØD				
	L	b°				
ETS 12	1.00- 7.00	11.00	1.00	17.00	8°	1412.0000
ETS 14	1.00 - 8.00	14.00	1.00	20.50	8°	1414.0000
ETS 16	1.00 - 10.00	16.00	1.00	24.00	8°	1416.0000
ETS 20	1.00 - 13.00	20.00	1.00	30.50	8°	1420.0000
ETS 25	1.00 - 16.00	25.00	1.00	34.00	8°	1425.0000
ETS 32	2.00 - 20.00	32.00	1.00	40.00	8°	1432.0000
ETS 40	4.00 - 26.00	40.00	1.00	45.00	8°	1440.0000

Reference Number
(Example: ETS 16 - Ø3.00)

1416.0300

In a world of imperfection, go for the least one



SWISS QUALITY MADE
tecnopinz



ETS HERMETIC COLLETS

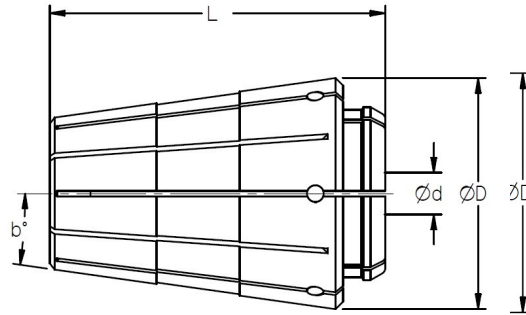
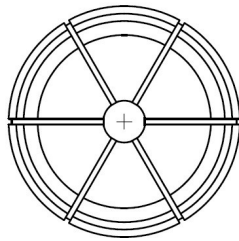

(Dimensions are in mm)

Type	$\varnothing d$	$\varnothing D$	Clamping Range	L	b°	Reference Number
Type	$\varnothing d$	$\varnothing D$	Plage de Serrage	L	b°	Numéro Référence
Typ	$\varnothing d$	$\varnothing D$	Spann Bereich	L	b°	Bestell Nummer
ETS 12	1.00 - 7.00	11.00	1.00	17.00	8°	1512.0000
ETS 14	1.00 - 8.00	14.00	1.00	20.50	8°	1514.0000
ETS 16	1.00 - 10.00	16.00	1.00	24.00	8°	1516.0000
ETS 20	1.00 - 13.00	20.00	1.00	30.50	8°	1520.0000
ETS 25	1.00 - 16.00	25.00	1.00	34.00	8°	1525.0000
ETS 32	2.00 - 20.00	32.00	1.00	40.00	8°	1532.0000
ETS 40	4.00 - 26.00	40.00	1.00	45.00	8°	1540.0000

Reference Number
 (Example: ETS 16 - $\varnothing 3.00$)

1516.0300

In a world of imperfection, go for the least one

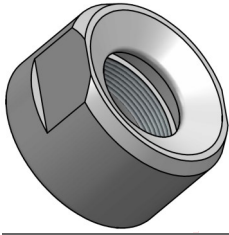

SWISS QUALITY MADE
tecnopin



ETS NUTS

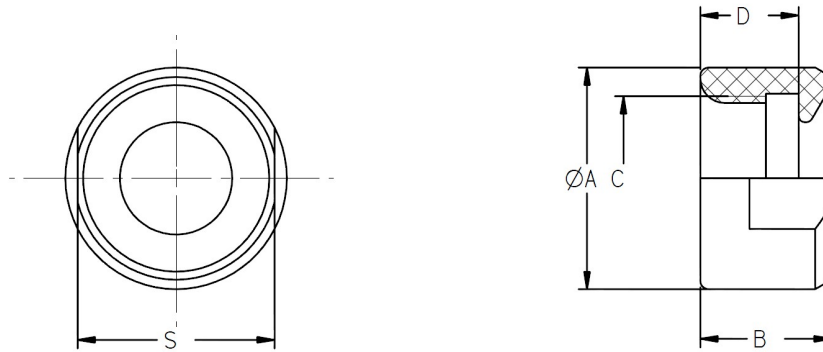

(Dimensions are in mm)

Type Type Typ	ØA	B	C	WS 	D	Used on Collet Pour Pince Für Spannzange	Reference Number Numéro Référence Bestell Nummer
ETS 6 ETS 6.1	14.00 10.50	8.00 8.00	M10 x 0.50 M8 x 0.50	13 9	6.00 6.00	ETA 6	2006.0000 2006.1000
ETS 8 ETS 8.1	18.00 12.50	8.00 8.00	M14 x 1.00 M10 x 0.75	17 11	6.00 6.00	ETA 8	2008.0000 2008.1000
ETS 9 ETS 9.1	13.50 15.00	8.00 8.00	M10 x 0.75 M11 x 0.75	12 13	6.00 6.00	ETS 9	2009.0000 2009.1000
ETS 10 ETS 10.1	18.00 15.00	8.00 8.00	M14 x 1.00 M12 x 0.75	17 13	6.00 6.00	ETA 10 / ETS 10	2010.0000 2010.1000
ETS 12 ETS 12.1 ETS 12.2 ETS 12.7	19.00 18.00 25.00 25.00	12.00 12.00 12.50 12.50	M14 x 0.75 M13 x 0.75 M18 x 1.50 M14 x 0.75	17 16 22 17	9.00 9.00 10.00 10.00	ETA 12 / ETS 12	2012.0000 2012.1000 2012.2000 2012.7000
ETS 16.1 ETS 16.2 ETS 16.3 ETS 16.4	26.50 24.70 26.70 30.00	15.00 15.00 15.00 12.00	M22 x 1.50 M19 x 1.00 M20 x 1.00 M22 x 1.50	25 22 24 26	11.00 11.00 11.00 9.00	ETA 16 / ETS 16	2016.1000 2016.2000 2016.3000 2016.4000
ETS 20.1 ETS 20.2	32.00 32.00	16.50 16.50	M24 x 1.00 M25 x 1.50	28 28	12.00 12.00	ETS 20	2020.1000 2020.2000

Reference Number
(Example: ETS16 M22x1.50)

2016.1000

In a world of imperfection, go for the least one



SWISS QUALITY MADE
tecnopin



ETS NUTS

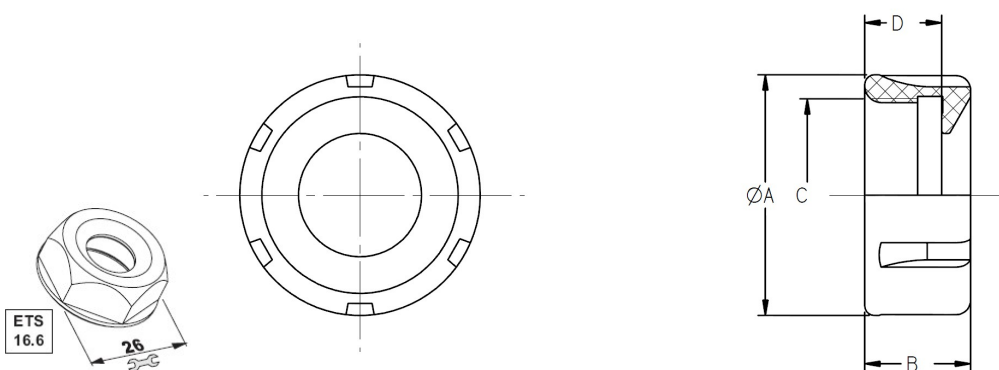

(Dimensions are in mm)

Type Type Typ	ØA	B	C	D	Used on Collet Pour Pince Für Spannzange	Reference Number Numéro Référence Bestell Nummer
ETS 14	22.00	11.20	M17 x 1.00	8.70	ETS14	3014.0000
ETS 16 ETS 16.6	32.00 30.00	15.00 12.00	M22 x 1.50 M22 x 1.50	11.00 9.00	ETS 16 / ETA 16 ETS 16 / ETA 16	3016.0000 3016.6000
ETS 20	35.00	16.50	M25 x 1.50	12.00	ETS 20	3020.0000
ETS 25 ETS 25.1	42.00 42.00	18.50 18.50	M32 x 1.50 M30 x 1.00	14.00 14.00	ETS 25 ETS 25	3025.0000 3025.1000
ETS 32	50.00	22.00	M40 x 1.50	16.00	ETS 32	3032.0000
ETS 40	63.00	25.00	M50 x 1.50	18.50	ETS 40	3040.0000

Reference Number

3020.0000

In a world of imperfection, go for the least one



SWISS QUALITY MADE
tecnopinz



ETS LEFT THREAD NUTS

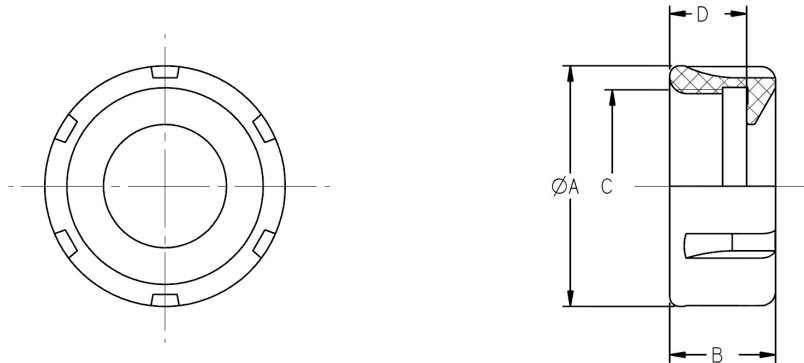

(Dimensions are in mm)

Type Type Typ	ØA	B	C	D	Used on Collet Pour Pince Für Spannzange	Reference Number Numéro Référence Bestell Nummer
ETS 25.2	42.00	18.50	M32 x 1.50	14.00	ETS 25	3025.2000
ETS 25.3	42.00	18.50	M30 x 1.00	14.00	ETS 25	3025.3000
ETS 32.1	50.00	22.00	M40 x 1.50	16.00	ETS 32	3032.1000
ETS 40.1	63.00	25.00	M50 x 1.50	18.50	ETS 40	3040.1000

Reference Number
 (Example: ETS32 M40x1.50)

3032.1000

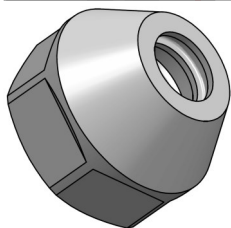

SWISS QUALITY MADE
tecnopin



ETS FLUID NUTS

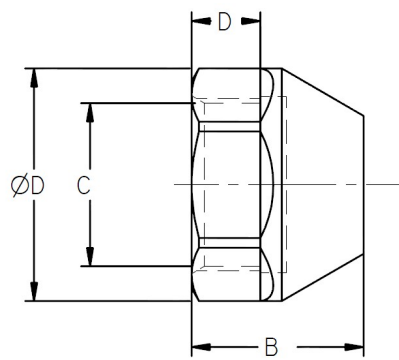
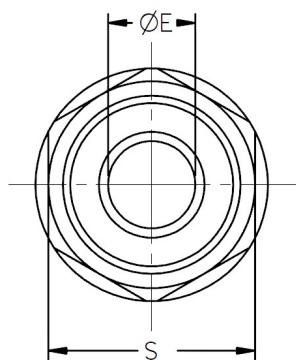

(Dimensions are in mm)

Type	ØD	ØE	B	C	D	Used on Collet	Reference Number
Type	ØD	ØE	B	C	D	Pour Pince	Número Réference
Typ	ØD	ØE	B	C	D	Für Spannzange	Bestell Nummer
ETS 16	27	8.00	20	M20 x 1.00	11	ETA16 / ETS16	4016.0800
	27	10.00	20	M20 x 1.00	11		4016.1000
ETS 20	32	10.00	22	M25 x 1.50	12	ETS 20	4020.1000
	32	12.00	22	M25 x 1.50	12		4020.1200
ETS 25	40	14.00	24.60	M32 x 1.50	14	ETS 25	4025.1400
	40	16.00	24.60	M32 x 1.50	14		4025.1600
ETS 32	50	18.00	27.50	M40 x 1.50	16	ETS32	4032.1800
	50	20.00	27.50	M40 x 1.50	16		4032.2000

Reference Number
(Example: ETS16 M20x1.00)

4016.1000

In a world of imperfection, go for the least one



SWISS QUALITY MADE
tecnopinz



ETS FLUID DISCS

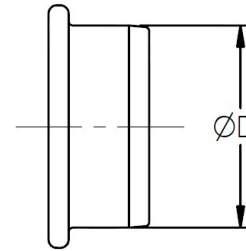
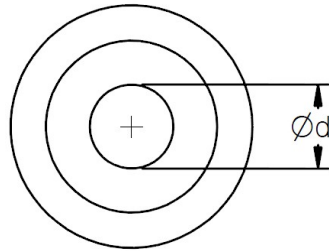

(Dimensions are in mm)

Type Type Typ	$\varnothing d$	Clamping Range Plage de Serrage Spann Bereich	$\varnothing D$	Used on Nut Pour Écrou Für Spannmutter	Reference Number Numéro Référence Bestell Number
ETS 16	3.00 - 6.00	1.00	10.00	ETA 16 / ETS 16	4116.0000
ETS 20	3.00 - 8.00	1.00	12.00	ETS 20	4120.0000
ETS 25	3.00 - 12.00	1.00	16.00	ETS 25	4125.0000
ETS 32	3.00 - 16.00	1.00	20.00	ETS 32	4132.0000

Reference Number
 (Example: ETS16 Ø3.00)

4116.0300

In a world of imperfection, go for the least one

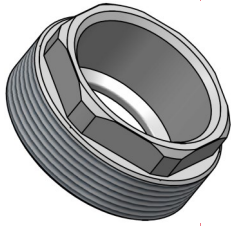

SWISS QUALITY MADE
tecnopinz



ETS EXTERNAL THREAD NUTS

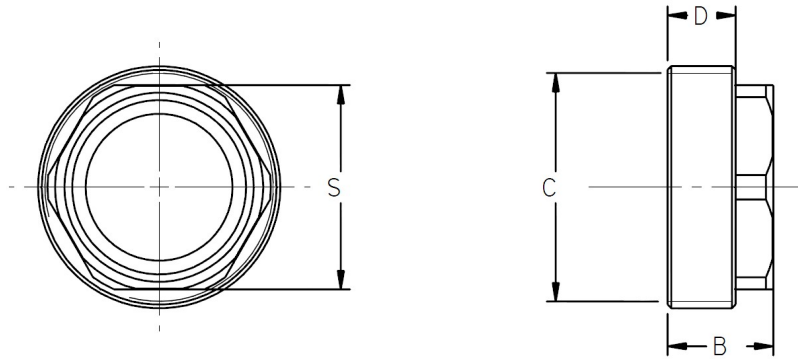

(Dimensions are in mm)

Type Type Typ	ØA	B	C	D	Used on Collet Pour Pince Für Spannzange	Reference Number Numéro Référence Bestell Nummer
ETS 16	12.00	M24 x 1.00	7.00	21	ETS 16 / ETA 16	5016.0000
ETS 20	13.00	M28 x 1.50	8.00	25	ETS 20	5020.0000
ETS 25	14.00	M32 x 1.50	9.00	27	ETS 25	5025.0000
ETS 32	15.00	M40 x 1.50	10.00	35	ETS 32	5032.0000

Reference Number

5016.0000

In a world of imperfection, go for the least one

